

Guardrail



Table of Contents

1. Guardrail Highway & Bridge Standard Dimensions
2. Highway Guardrail Set Out
3. 3 Cable BCT Termination
4. Fish Tail Termination
5. Steel Post for Highway Rail
6. RHS Steel Post for Bridge Rail
7. Steel Post for Bridge Rail including Hand Rail Plate
8. Steel Post Hold Down Bracket

Highway Rail Overall Length 4128mm. Effective Cover 3810mm Thickness 2.7mm

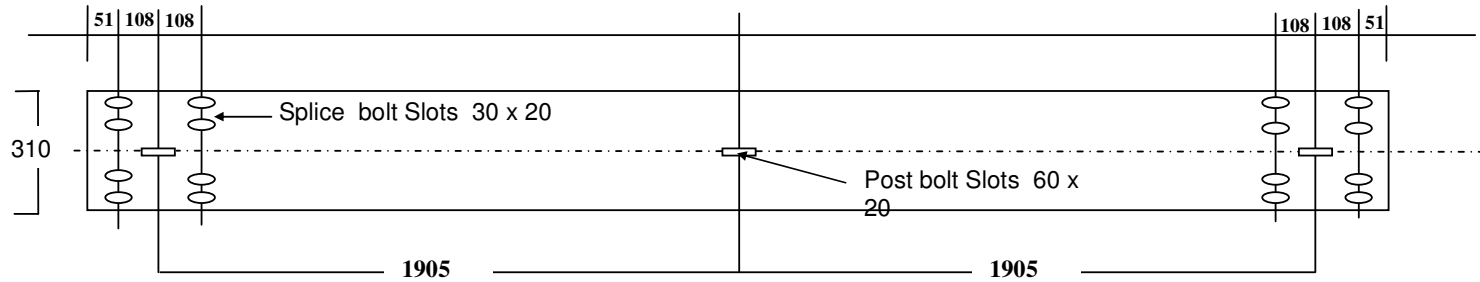

Bridge Rail Overall Length 4318mm. Effective Cover 4000mm. Thickness 3.4mm

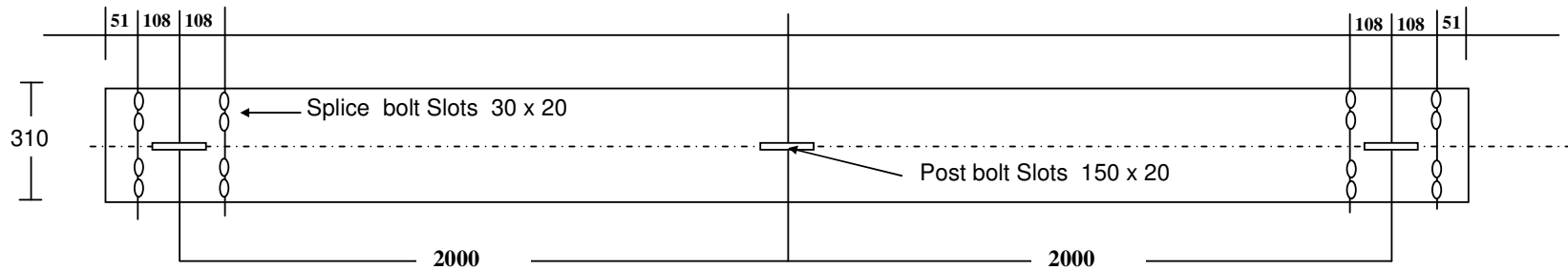

This drawing and the information contained herein is the sole property of STEELGAL INDUSTRIES LTD, is strictly confidential and must not be used or disclosed without the written consent of Steelgal Industries Ltd.

All dimensions are subject to manufacturing tolerances

Steelgal Industries Ltd.
P. O. Box 251055
Pakuranga. Auckland
Ph. (09) 272-4665. Fax (09) 272-4669
e-mail steelgal@xtra.co.nz

Product.

Guard Rail Hi-way & Bridge

Client.

Drawing No.

GR-1

Date July. 07

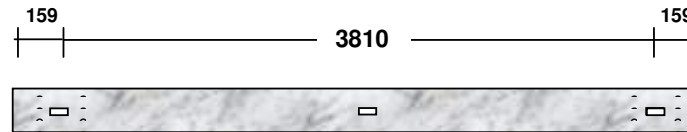
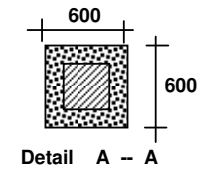
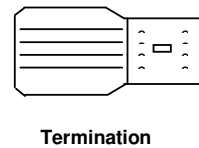
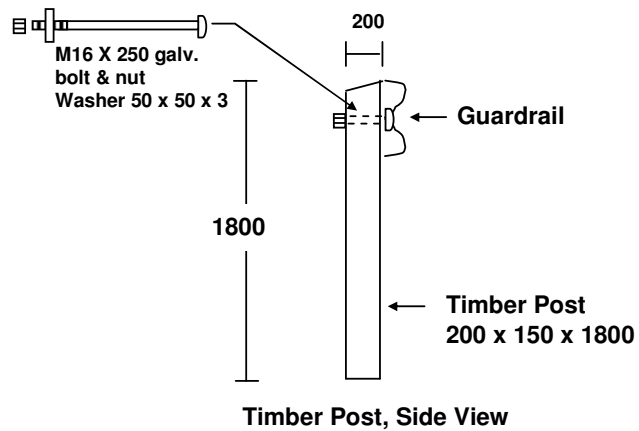
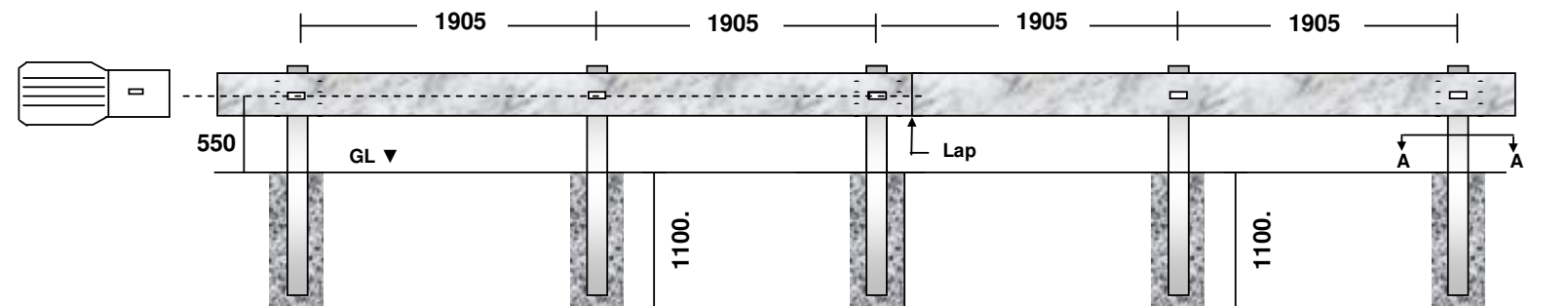

Standard Length Highway Rail.
Effective cover 3.810m
Lap in direction of traffic

This drawing and the information contained herein is the sole property of STEELGAL INDUSTRIES LTD, is strictly confidential and must not be used or disclosed without the written consent of Steelgal Industries Ltd.

All dimensions are subject to manufacturing tolerances

Steelgal Industries Ltd.
P. O. Box 251055
Pakuranga. Auckland
Ph. (09) 272-4665. Fax (09) 272-4669
e-mail steegal@xtra.co.nz

Product. Highway Guardrail
Contract Layout detail
Client.
Drawing No. GR-1

Date July 07

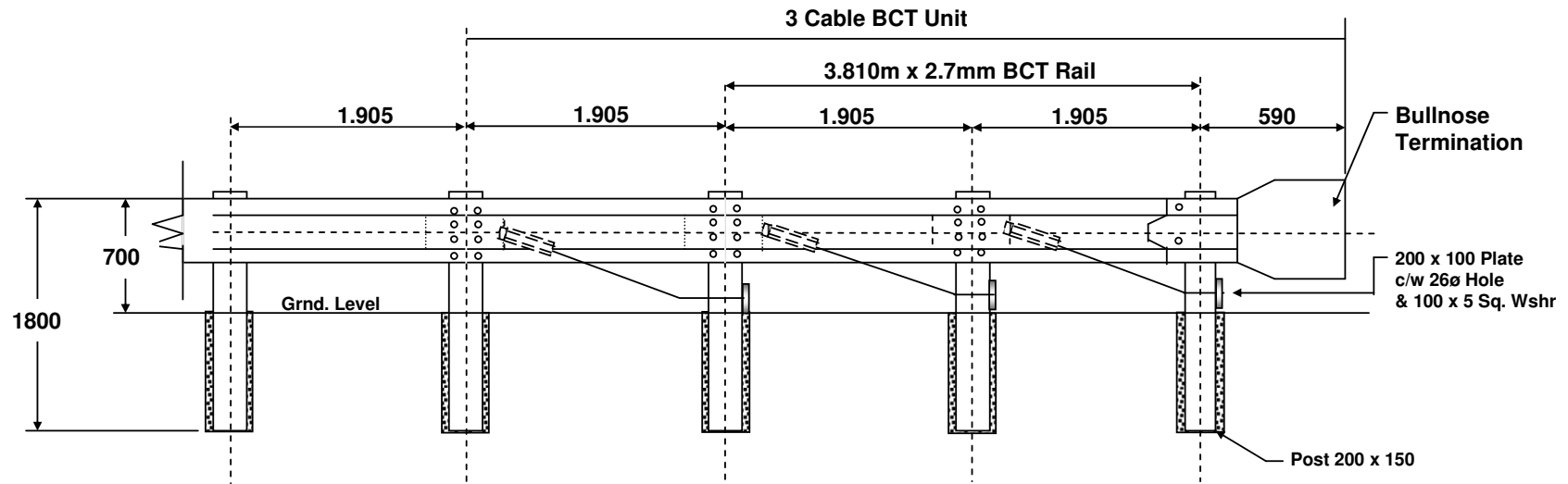

This drawing and the information contained herein is the sole property of STEELGAL INDUSTRIES LTD, is strictly confidential and must not be used or disclosed without the written consent of Steelgal Industries Ltd.

All dimensions are subject to manufacturing tolerances

Steelgal Industries Ltd.
P. O. Box 251055
Pakuranga. Auckland
Ph. (09) 272-4665. Fax (09) 272-4669
e-mail steelgal@xtra.co.nz

Product.
Contract
Client.
Drawing No.

3 Cable BCT
GRBCT- 3

Date Nov. 98

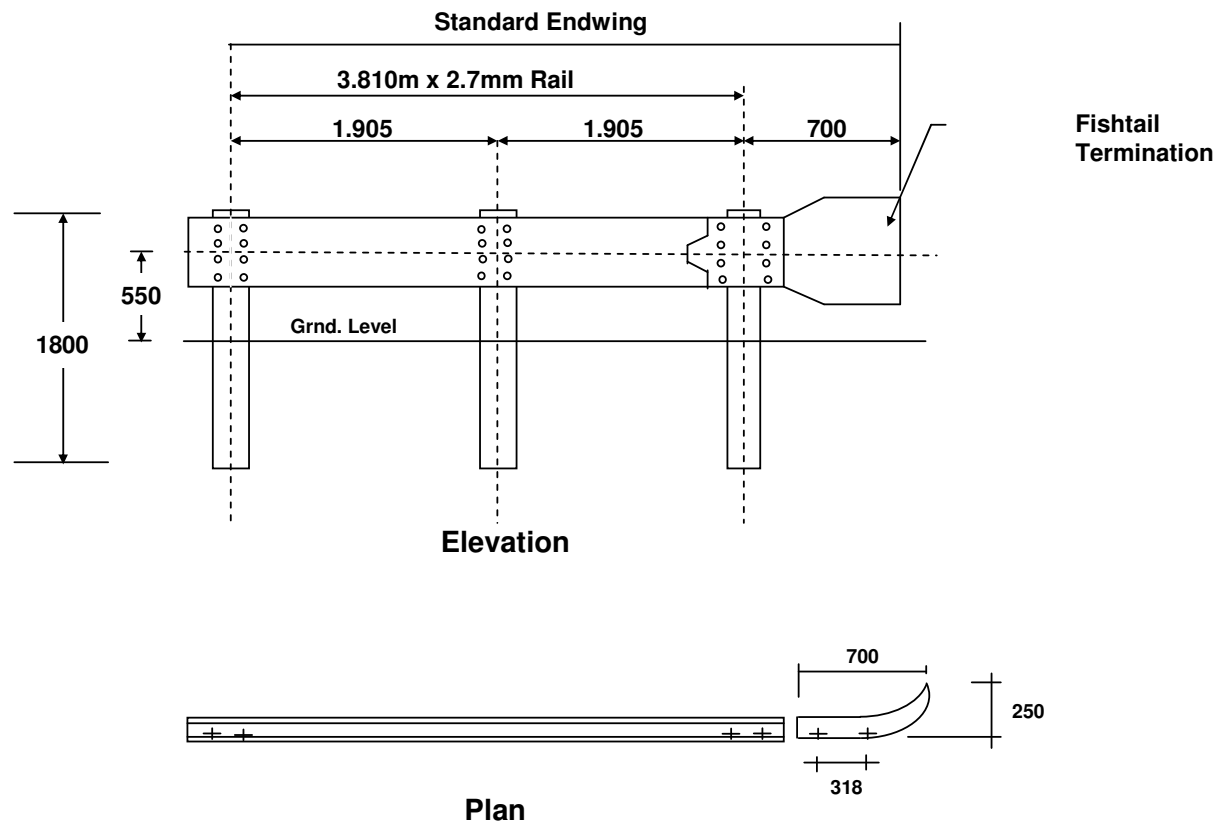

This drawing and the information contained herein is the sole property of STEELGAL INDUSTRIES LTD, is strictly confidential and must not be used or disclosed without the written consent of Steelgal Industries Ltd.

All dimensions are subject to manufacturing tolerances

Steelgal Industries Ltd.
P. O. Box 251055
Pakuranga. Auckland
Ph. (09) 272-4665. Fax (09) 272-4669
e-mail steelgal@xtra.co.nz

Product.
Contract
Client.
Drawing No.

Standard Fishtail

GREW

Date June. 07

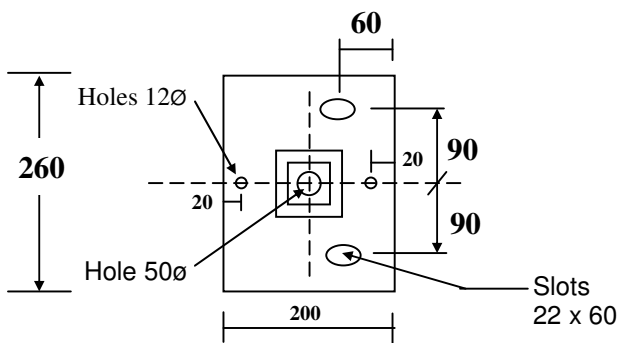
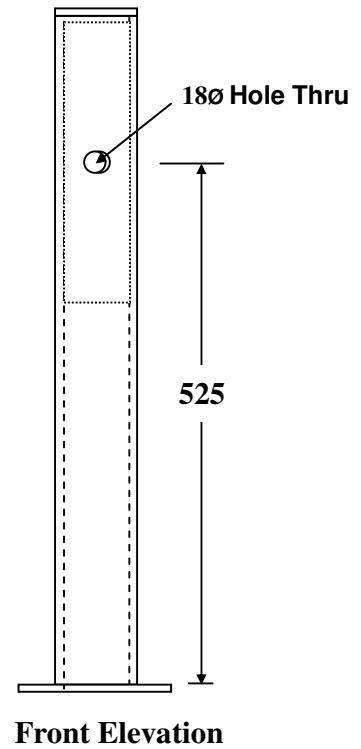
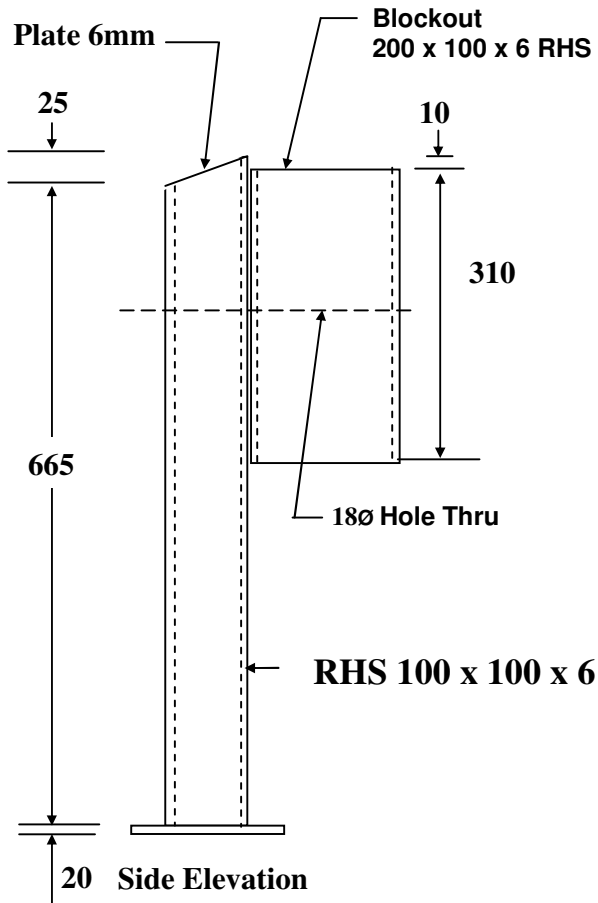

This drawing and the information contained herein is the sole property of STEELGAL INDUSTRIES LTD, is strictly confidential and must not be used or disclosed without the written consent of Steelgal Industries Ltd.

All dimensions are subject to manufacturing tolerances

Steelgal Industries Ltd.
P. O. Box 251055
Pakuranga. Auckland
Ph. (09) 272-4665. Fax (09) 272-4669
Email: steelgal@xtra.co.nz

Product: Steel Post
Client:
Contract:
Drawing No: SP690-H
Date: Feb 07

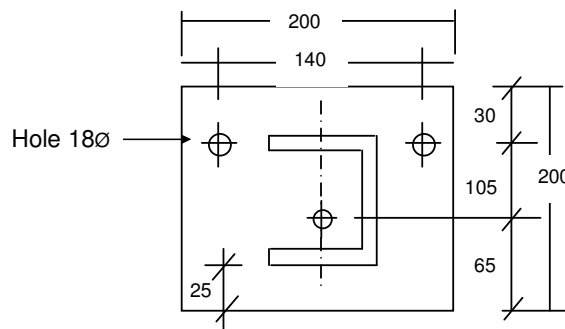
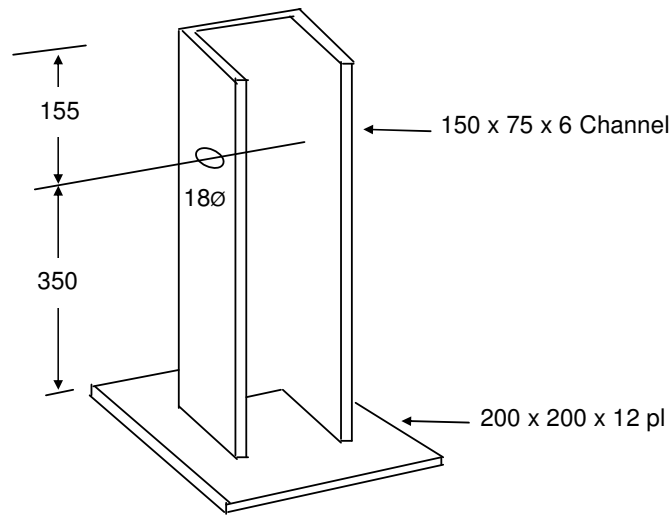

Base Plate

This drawing and the information contained herein is the sole property of STEELGAL INDUSTRIES LTD, is strictly confidential and must not be used or disclosed without the written consent of Steelgal Industries Ltd.

All dimensions are subject to manufacturing tolerances

Steelgal Industries Ltd.
P. O. Box 251055
Pakuranga. Auckland
Ph. (09) 272-4665. Fax (09) 272-4669
Email: steelgal@xtra.co.nz

Product: Steel Post Channel Type A
Client:
Contract:
Drawing No: SPC150/75
Date: June 05

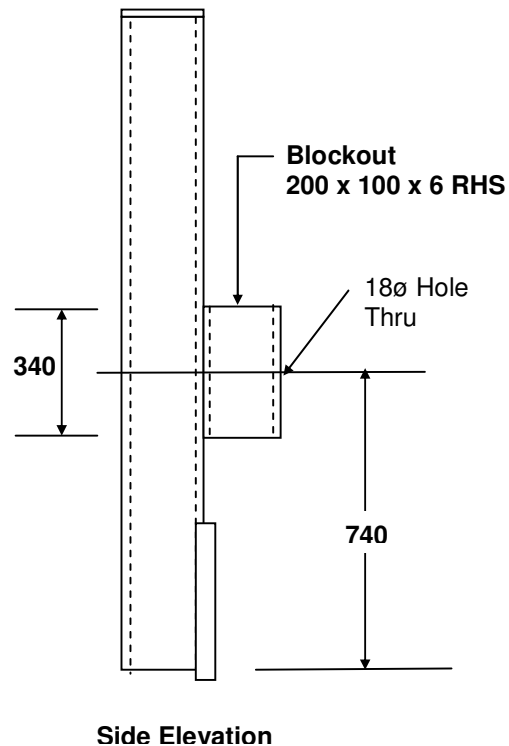
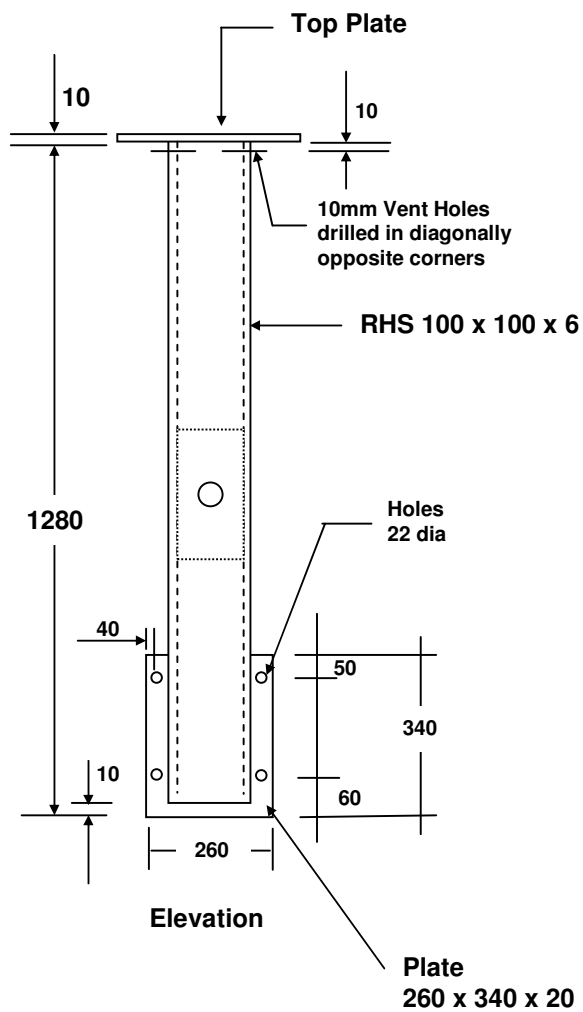
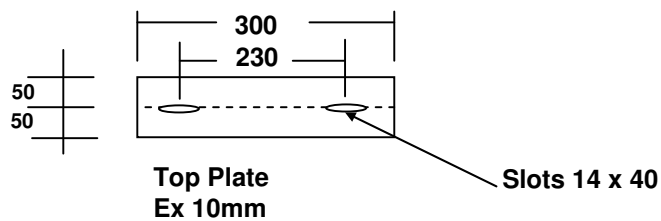

This drawing and the information contained herein is the sole property of STEELGAL INDUSTRIES LTD, is strictly confidential and must not be used or disclosed without the written consent of Steelgal Industries Ltd.

All dimensions are subject to manufacturing tolerances

Steelgal Industries Ltd.
P. O. Box 251055
Pakuranga. Auckland
Ph. (09) 272-4665. Fax (09) 272-4669
Email: steelgal@xtra.co.nz

Product: Steel Post / Handrail Plate
Client:
Contract:
Drawing No: SP1280/H/SM
Date: July 07

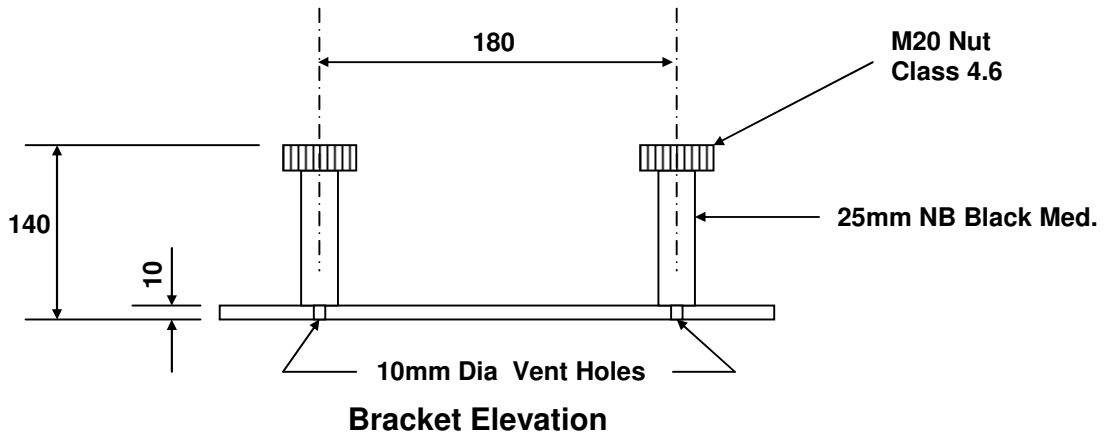
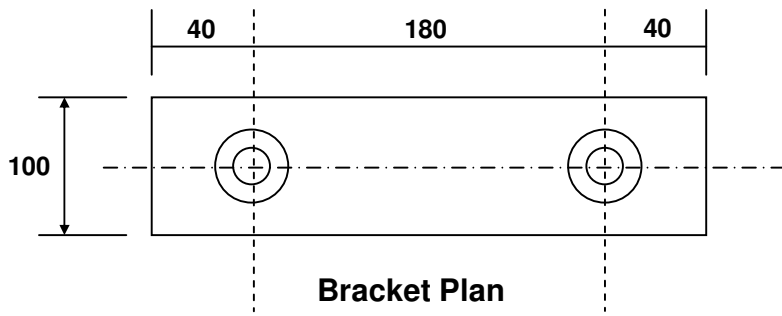

This drawing and the information contained herein is the sole property of STEELGAL INDUSTRIES LTD, is strictly confidential and must not be used or disclosed without the written consent of Steelgal Industries Ltd.

All dimensions are subject to manufacturing tolerances

Steelgal Industries Ltd.
 P. O. Box 251055
 Pakuranga. Auckland
 Ph. (09) 272-4665. Fax (09) 272-4669
 e-mail steelgal@xtra.co.nz

Product.	Steel Post Hold Down Bracket
Client.	
Drawing No.	HDB/SP
Date	July 07