

Street Lighting Columns

- Pg 2. Octagonal - Ground Planted
- Pg 3. Octagonal - Shear Based
- Pg 4. Octagonal –Flange Mounted
- Pg 5. Elliptical Outreaches

Standard Range Octagonal Street Lighting Columns. Ground Planted

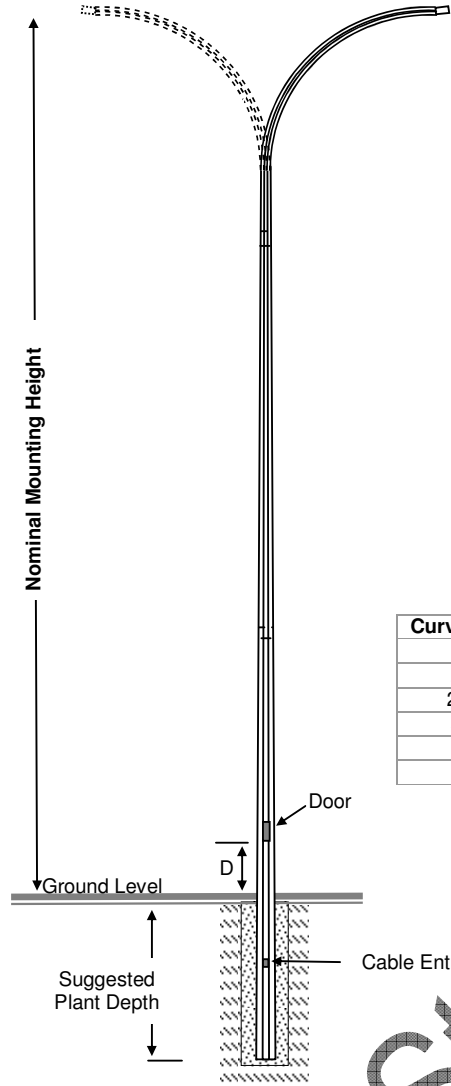

Nominal Mounting Height	Pole Sections	Pole Weight	D	Suggested Plant Depth
6m	2 + Outreach	49kg + Outreach	200	1200
7.0m	2 + Outreach	68kg + Outreach	450	1500
8.0m	2 + Outreach	85kg + Outreach	450	1700
9.0m	2 + Outreach	92kg + Outreach	300	1700
10.0m	3 + Outreach	123kg + Outreach	450	2000
11.0m	3 + Outreach	152kg + Outreach	300	2200
12.0m	3 + Outreach	162kg + Outreach	450	2200
13.0m	3 + Outreach	169kg + Outreach	450	2400
13.6m	4 + Outreach	198kg + Outreach	300	2400

Curved Outreach

1m – 4m

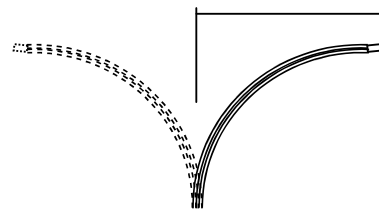

Curved Outreaches	Approximate Weight
1m Single Curved Outreach	11kg
2m Single Curved Outreach	13.5kg
2m Double Curved Outreach	27kg
3m Single Curved Outreach	17.5kg
3m Double Curved	38kg
4m Single Curved	28kg

Mitred Outreach

1m – 4m

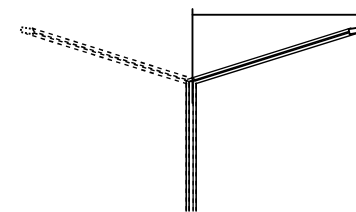

Mitred Outreaches	Approximate Weight
1m Single Mitred	11kg
2m Single Mitred	13.5kg
3m Single Mitred	17.5kg
3m Double Mitred	40kg
4m Single Mitred	28kg
4m Double Mitred	48kg

Custom outreaches are available on request

This drawing and the information contained herein is the sole property of STEELGAL INDUSTRIES LTD strictly confidential and must not be used or disclosed without the written consent of Steelgal Industries Ltd

All dimensions are subject to manufacturing tolerances

Steelgal Industries Ltd
 P. O. Box 251055 Pakuranga. 2140 Auckland
 Ph. (09) 276-6972. Fax (09) 276-6951
 e – mail info@steelgal.co.nz

Product.
Date

Octagonal Steel Standard Street Lighting Poles Ground Plant
 February 2007

Standard Range Octagonal Street Lighting Columns. Shear Base

Nom. Mounting Height	Pole Sections	Pole Weight	D	Base Flange
7.0m	3 + Outreach	84kg	450	450x 20
8.0m	3 + Outreach	94kg	450	450x 20
9.0m	3 + Outreach	109kg	300	450x 20
10.0m	3 + Outreach	131kg	450	450x 20
11.0m	3 + Outreach	150kg	300	450x 20
12.0m	3 + Outreach	174kg	300	450x 20

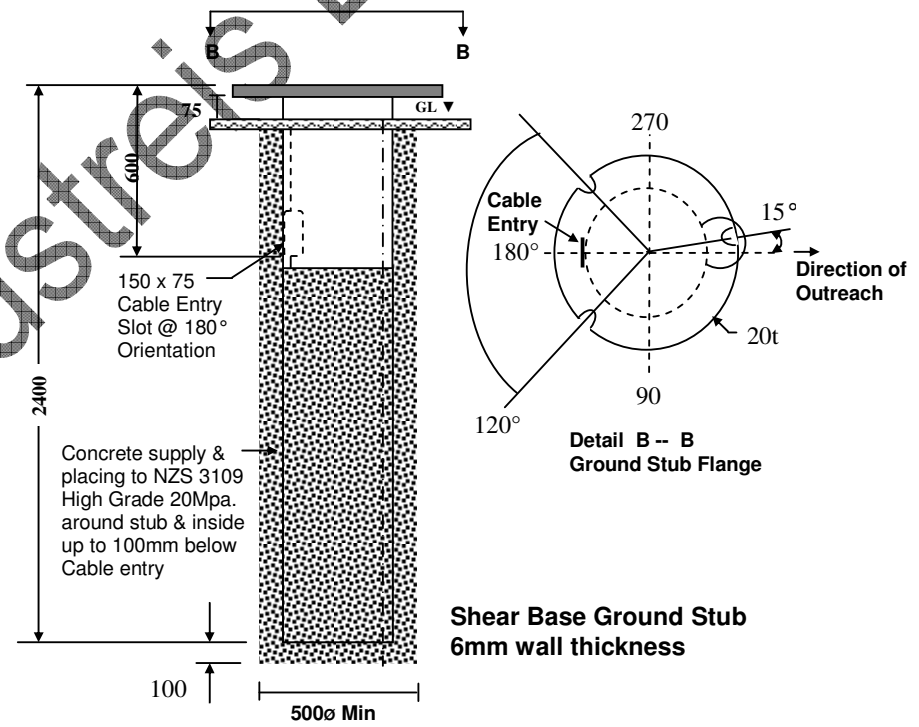
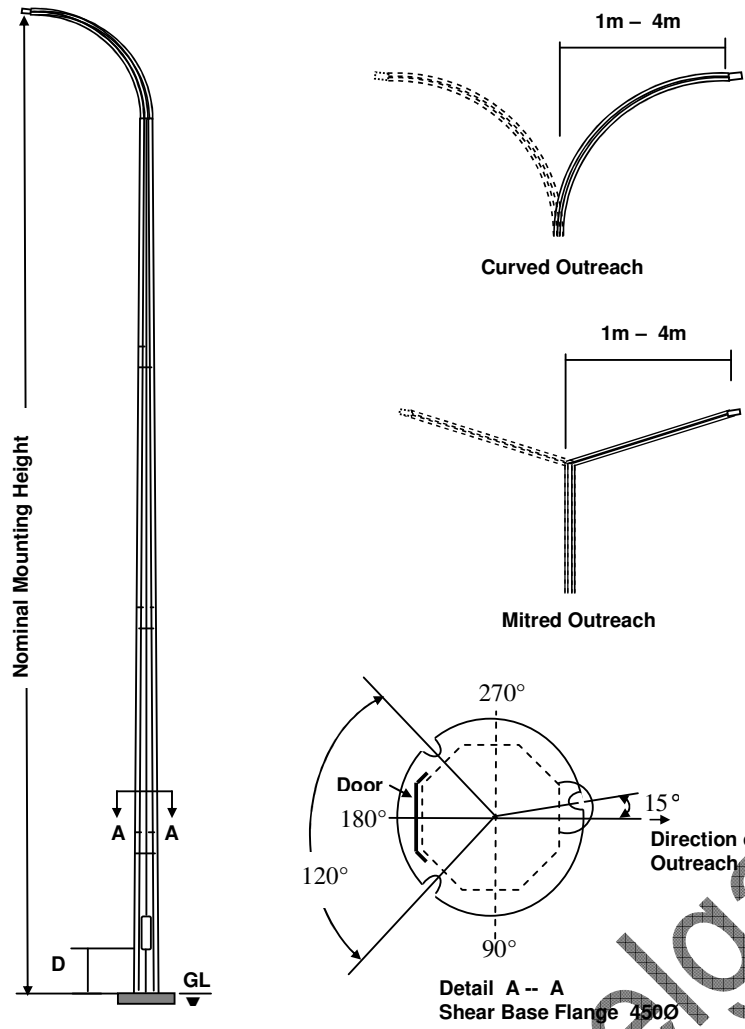

This drawing and the information contained herein is the sole property of STEELGAL INDUSTRIES LTD, is strictly confidential and must not be used or disclosed without the written consent of Steelgal Industries Ltd.

All dimensions are subject to manufacturing tolerances

Steelgal Industries Ltd.
 P. O. Box 251055 Pakuranga. 2140 Auckland
 Ph. (09) 276-6972. Fax (09) 276-6951
 e - mail info@steelgal.co.nz

Product. Octagonal Steel Standard Street Lighting Poles Shear Base

Date July 06

Standard Range Octagonal Street Lighting Columns. Flanged Base

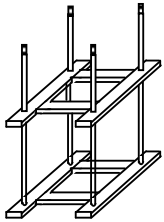

**Hold Down Cage
for poles up to 12.0m**

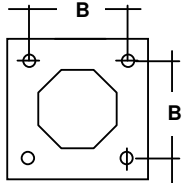

Detail A -- A

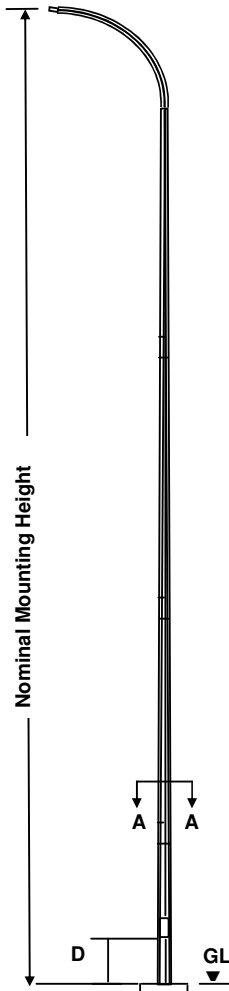

Nom. Mounting Height Curved / Mitred	Pole Sections	Approx Pole Weight (kg)	D (mm)	Base Flange (mm)	B (mm)	Hole Ø (mm)
10.0m	3 + Outreach	111	450	375 x 375 x 20	260	26
11.0m	3 + Outreach	121	450	375 x 375 x 20	260	26
11.9m	3 + Outreach	145	300	450 x 450 x 20	320	30
12.0m	3 + Outreach	128	450	375 x 375 x 20	260	26
12.8m	3 + Outreach	155	300	450 x 450 x 20	320	30
13.7m	3 + Outreach	162	300	450 x 450 x 20	320	30

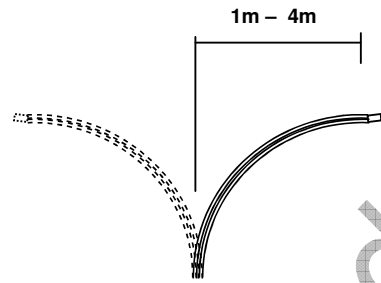

Curved Outreaches
Single or Double
Triple outreaches available

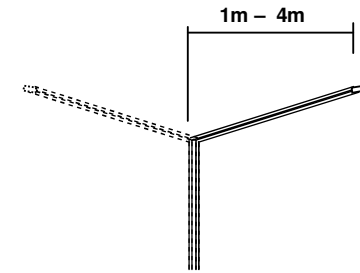

Mitred Outreaches
Single or Double
Triple outreaches available
on request

This drawing and the information contained herein is the sole property of STEELGAL INDUSTRIES LTD, is strictly confidential and must not be used or disclosed without the written consent of Steelgal Industries Ltd.

All dimensions are subject to manufacturing tolerances

Steelgal Industries Ltd.
P. O. Box 251055 Pakuranga 2140. Auckland
Ph. (09) 276-6972. Fax (09) 276-6951
e – mail: info@steelgal.co.nz

Product. Octagonal Steel Standard Street Lighting Poles Flanged Base

Date February 2007

Octagonal Street Lighting Columns.

Elliptical Outreaches

Elliptical Outreach are available for Ground Plant, Flanged and Shear Base Columns

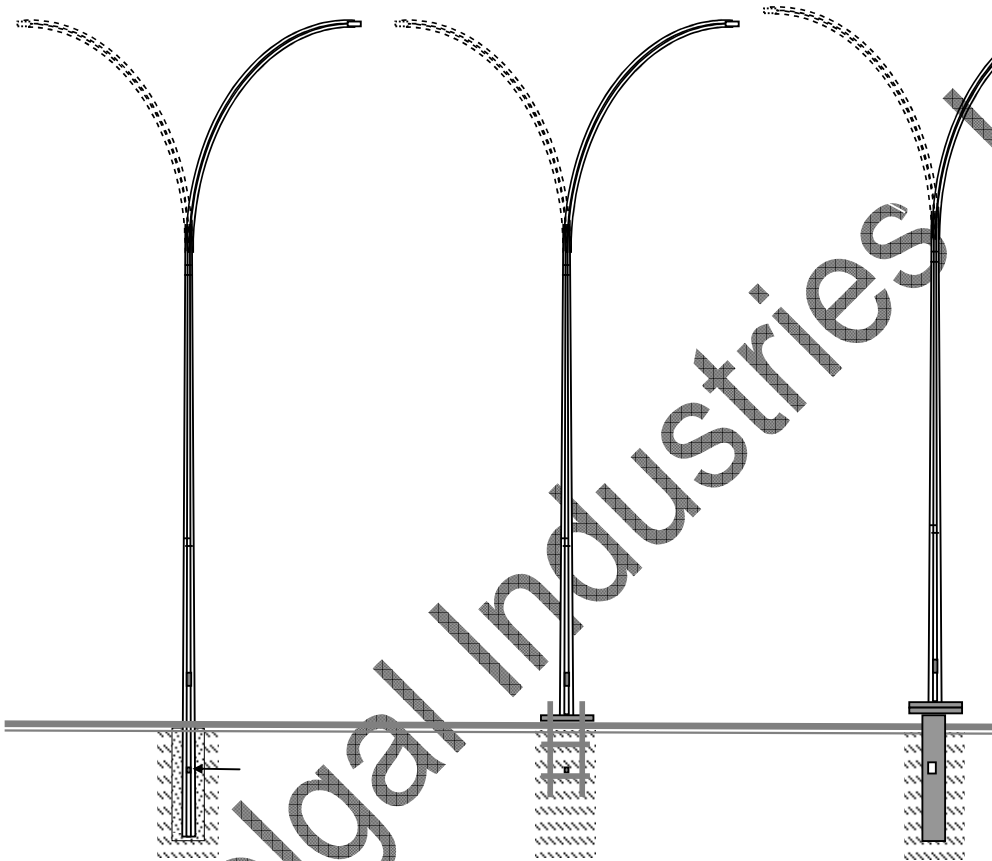

This drawing and the information contained herein is the sole property of STEELGAL INDUSTRIES LTD strictly confidential and must not be used or disclosed without the written consent of Steelgal Industries Ltd

All dimensions are subject to manufacturing tolerances

Steelgal Industries Ltd
P. O. Box 251055 Pakuranga. 2140 Auckland
Ph. (09) 276-6972. Fax (09) 276-6951
e – mail info@steelgal.co.nz

Product: Octagonal Steel Standard Street Lighting Poles with Elliptical Outreaches are available on request
Date February 2007